

AP-PS3265P868 Specification Version 1.0

Introduction

1.1 Scope

This specification defines the performance and characteristic for the model of AP-PS3265P868.

1.2 General Description

AP-PS3265P868 is a 650W Power Supply.

It features Active PFC (Power Factor Correction) circuits with Full Range Input and meets 62368 UL & TUV standards. Support 80 Plus Platinum

2. AC Input

2.1 Voltage Range

Voltage range: 100VAC min ~ 264VAC max, Active PFC Version

2.2 Frequency Range

Frequency range: 47Hz – 63Hz

2.3 Input Current

2.3.1 Steady-state Current

Maximum current at 110 VAC (RMS): 9.0A

Maximum current at 240 VAC (RMS): 4.5 A

2.3.2 Cold Start Inrush Current

Maximum inrush current at 115 VAC: 50A

Maximum inrush current at 230 VAC: 100A

* Measured at 25 °C ambient cold start.

2.3.3 Power Factor Correction (PFC)

115V (Nominal) Operation

PFC reaches 95.0% at 115V, 60Hz, under full output loading in accordance with the EN 61000-3-2, class D standards.

230V (Nominal) Operation

PFC reaches 95.0% at 230V, 50Hz, under full output loading in accordance with the EN 61000-3-2, class D standards.

2.4.4 Input Over current Protection

The POWER SUPPLY is equipped with a non-reset-able fuse on the AC input to limit power consumption on a failure within the power supply module.

Input Fuse Rating:

Voltage	250 V
Current	12 A

2.4.5 Withstand Voltage

The POWER SUPPLY is capable of withstanding a maximum 1800vac potential between the input and ground for a period of 1 minute.

2.4.6 Catastrophic Failure Protection

If a component failure occurs, the POWER SUPPLY will not exhibit any of the following:

- * Flame
- * Excessive smoke
- * Charred PCB
- * Fused PCB conductor
- * Startling noise
- * Emission of molten material

2.47 AC Line transient Specification

AC line transient conditions shall be defined as “sag” and “surge” conditions.

“Sag” conditions are also commonly referred to as “brownout”,

these conditions will be defined as the AC line voltage dropping below nominal voltage conditions.

“Surge” will be defined to refer to conditions when the AC line voltage rises above nominal voltage.

The power supply shall meet the requirements under the following AC line sag and surge conditions.

AC Line SAG transient performance.

AC Line Sag (10sec interval between each sagging)				
Duration	Sag	Operating AC voltage	Line frequency	Performance criteria
0 to 1/2 AC cycle	95%	Nominal AC voltage	50/60Hz	No loss of function or performance
>1 AC cycles	>30%	Nominal AC voltage	50/60Hz	Loss of function acceptable, self-recoverable

AC Line SURGE transient performance.

AC Line Surge				
Duration	Surge	Operating ac voltage	Line frequency	Performance criteria
Continuous	10%	Nominal AC voltage	50/60Hz	No loss of function or performance
0 to 1/2 AC cycle	30%	mid-point of nominal AC voltage	50/60Hz	No loss of function or performance

3. DC Output

3.1 Output Voltage

Table 1 below summarizes the minimum DC output voltages and associated power requirements for each output.

Table 1. DC Output Specifications:

Parameter	Min (A)	Nom.	Max (A)	Unit
+3.3V	0.3	-	20	Amps
+5V	0.5	-	20	Amps
+12V	0.3	-	53	Amps
-12V	0.0	-	0.3	Amps
+5VSB	0.0	-	2.5	Amps

Notes: The maximum continuous total DC outputs power shall not exceed 650W.

3.2 Output Regulation

The DC voltage outputs will stay within the regulation band as measured at the terminal outputs due to any combination of the following conditions:

- Input voltage fluctuations
- Specified load range
- Centering
- Specified environmental conditions
- Changing load steps

3.2.1 Output voltage load regulation

The following table summarizes the allowable output voltage tolerances for each output rail.

Table 2. DC Output Tolerance Specifications

DC Nominal Output	Output Voltage Tolerance
+3.3V	±5%
+5V	±5%
+12V	±5%
-12V	±10%
+5VSB	±5%

3.2.2 Output Voltage Line Regulation

The following table specifies line regulation as measured from minimum to maximum load including the transient response requirements as detailed in this document.

Table 3. DC Output Tolerance Specifications

DC Nominal Output	Output Voltage Tolerance
+12V	±1%
+5V	±1%
+3.3V	NA
-12V/-5V	±1%
+5VSB	NA

3.2.3 Cross Regulation

The POWER SUPPLY DC outputs perform within all line and load specifications regardless of the static or transient loads on any of the outputs.

3.3 Efficiency

≧ 89% minimum at 115VAC, at full load. Support 80 Plus Platinum

3.4 Output Periodic and Random Deviation (PARD)

There are two types of noise (PARD) specifications to be considered on the power supply;

Common Mode and Differential Mode. Common mode is referred to as noise that is common between the specified voltage output and the associated ground line.

Differential mode refers to noise that is only measured on the specified DC voltage output.

In either case, noise is within the frequency range of 10 Hz – 20MHz and specifications are rated over the full output range for the power supply.

Table 4. DC Output Periodic and Random Deviation (PARD)

DC Output	Ripple and Noise
+12V	120mv(pk-pk)
+5V	50mv(pk-pk)
+5VSB	50mv(pk-pk)
-12V	120mv(pk-pk)
+3.3V	50mv(pk-pk)

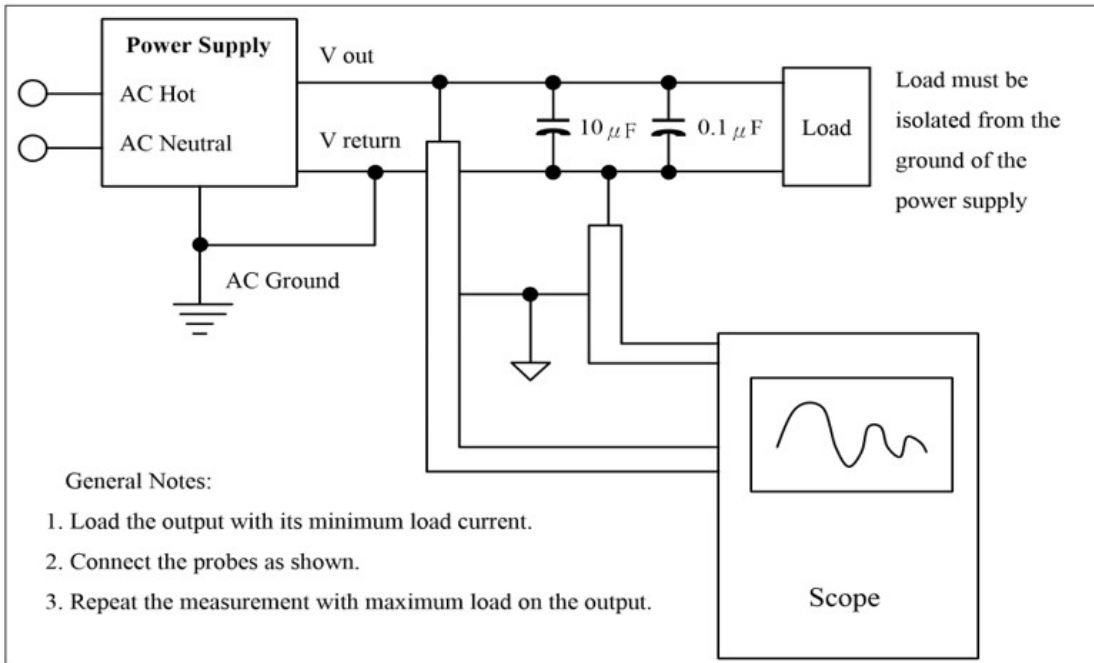

3.5 Voltage Hold-up Time

All output will stay within regulation for at least 17ms after an AC line voltage failure is detected at nominal line (115VAC or 230VAC) under 80% full load condition.

3.6 Timing / Housekeeping / Control

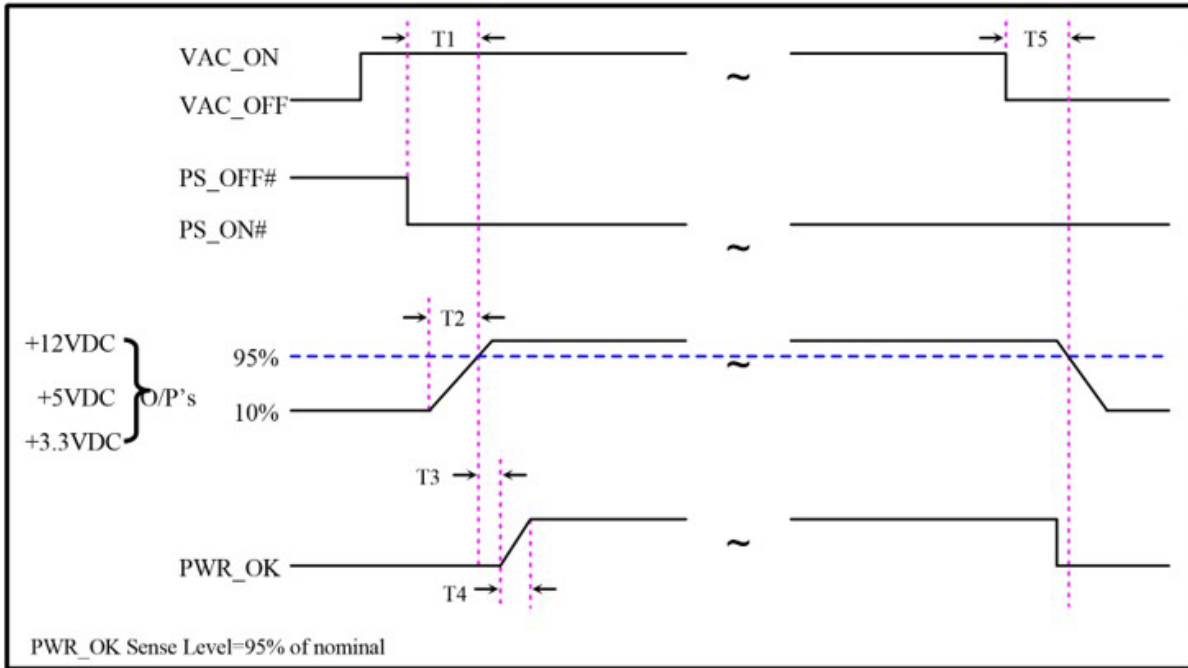

$< 500\text{mS}$	T1 : Power-On Time
$0.1\text{mS} \leq T2 \leq 20\text{mS}$	T2 : Rise Time
$100\text{mS} < T3 < 500\text{mS}$	T3 : PWR_OK Delay
$T4 \leq 100\mu\text{S}$	T4 : PWR_OK Rise Time
$T5 \geq 17\text{mS}$	T5 : AC Loss to PWR_OK Hold-up Time

Figure 1

Power Supply Timing

3.7.1 Output Rise time

The output voltages rise from 10% of nominal to within the regulation ranges within 0.1ms to 20ms (Figure 1)

3.7.2 Overshoot at Turn-on / Turn-off

Any overshoot at turn on or turn off is under 10% of the nominal DC output voltage with further stipulation that all DC outputs are within their specified DC voltage ranges before the generation of the power good signal.

Additionally, no voltage may undershoot or overshoot once the power good signal has been asserted.

3.7.3 Reset after Shutdown

The power supply latches into a shutdown state because of a fault condition on its outputs, the power supply returns to normal operating after the fault has been removed.

3.8 Output Protection

Each DC output is protected from over voltage, over current and short circuit. The following sections include the details for these protection mechanisms.

3.8.1 Over Current Protection

The power supply DC outputs are protected from supplying output current above the maximum ratings.

All DC outputs +12V1/+12V2/+5V are latched off in the event of an over-current event on the DC outputs.

In the event of a short circuit on any output, all outputs are disabled until the power supply is powered off back on.

3.8.2 Over Voltage Protection

The over voltage sense circuitry and reference reside in packages that are separate and distinct from the regulator control circuitry and reference. No single point fault is able to cause a sustained over voltage condition on any or all outputs. The power supply provides latch-mode over voltage protection defined as:

+5V output is between 5.8V to 6.3V

+12V output is between 13.5V to 16.0V

3.8.3 Short Circuit Protection

The Power Supply DC outputs are protected from damage due to faults, when any output shorts to ground.

In the event of a short circuit on any DC output, all outputs shall be disabled and remain disable until the Power Supply is powered off and back on.

4.2 Environmental

4.2.1 Environmental (Operating)

Temperature: 0°C to 40°C
Humidity: 20% to 80%
Relative Humidity (non-condensing)
Altitude: -61meters to +3,048 meters

4.2.2 Environmental (Non-Operating)

Temperature: -25 °C to 85 °C
Humidity: 10% to 90%
Relative Humidity (non-condensing)
Altitude: -61meters to +15,244 meters

4.3 Fan Control Function (Optional)

In order to prolong the fan's life cycle, the power supply is facilitated with a Thermostatic circuitry to control the fan speed under the power supply operating temperature and loading.

4.4 Reliability

The power supply reliability is based on the calculation with the Part-Stress Analysis method of MIL-HDBK-217F using the quality factors listed in MILHDBK-217F. under the following conditions:

Full-rated load
120VAC input
Ground begins
25 °C ambient

4.5 MTBF (Mean Time Between Failures) Calculation

The demonstrated MTBF shall be 100,000 hours of continuous operation at 25 °C , full load, 80% confidence limit and nominal line.

The MTBF of the power supply be calculated in accordance with MIL-HDBK-217F. The DC FAN is not included.

4.6 Safety / Agency Approval



4.7 Output Cable Pin assignment

AP-PS3265P868 Output Connector Pin Assignment Table

Ref ID	Pin No	Color Code	Signal	AWG#	Length (mm)		
Cable 1 ATX 24 Pin	24	Black	GND	18	500 +/- 20		
	23	Red	+5V	18			
	22	Red	+5V	18			
	21	Red	+5V	18			
	20	White	-5V	18			
	19	Black	GND	18			
	18	Black	GND	18			
	17	Black	GND	18			
	16	Green	PS_ON	18			
	15	Black	GND	18			
	14	Blue	-12V	18			
	13	Orange	+3.3V	18			
	12	Brown	+3.3VS	22			
	12	Orange	+3.3V	18			
	11	Yellow	+12V	18			
	10	Yellow	+12V	18			
	9	Purple	+5VSB	18			
	8	Gray	PG	18			
	7	Black	GND	18			
	6	Red	+5V	18			
	5	Black	GND	18			
	4	Red	+5V	18			
	3	Black	GND	18			
	2	Orange	+3.3V	18			
1	Orange	+3.3V	18				
Cable 2 8 Pin	8	Yellow	+12V	18	500 +/- 20		
	7	Yellow	+12V	18			
	6	Yellow	+12V	18			
	5	Yellow	+12V	18			
	4	Black	GND	18			
	3	Black	GND	18			
	2	Black	GND	18			
	1	Black	GND	18			
Cable 2 4+4 Pin	4	Yellow	+12V	18	150 +/- 15		
	3	Yellow	+12V	18			
	2	Black	GND	18			
	1	Black	GND	18			
Cable 3 6+2 Pin PCIE	8	Black	GND	18	500 +/- 20		
	7	Black	GND	18			
	6	Black	GND	18			
	5	Black	GND	18			
	4	Black	GND	18			
	3	Yellow	+12V	18			
	2	Yellow	+12V	18			
	1	Yellow	+12V	18			
Cable 3 6+2 Pin PCIE	8	Black	GND	18	150 +/- 15		
	7	Black	GND	18			
	6	Black	GND	18			
	5	Black	GND	18			
	4	Black	GND	18			
	3	Yellow	+12V	18			
	2	Yellow	+12V	18			
	1	Yellow	+12V	18			
Cable 4 SATA 15 Pin	13-15	Yellow	+12V	18	500 +/- 20		
	10-12	Black	GND	18			
	7-9	Red	+5V	18			
	4-6	Black	GND	18			
	1-3	Orange	+3.3V	18			
	13-15	Yellow	+12V	18		150 +/- 15	
	10-12	Black	GND	18			
	7-9	Red	+5V	18			
	4-6	Black	GND	18			
	1-3	Orange	+3.3V	18			
	13-15	Yellow	+12V	18			150 +/- 15
	10-12	Black	GND	18			
7-9	Red	+5V	18				
4-6	Black	GND	18				
1-3	Orange	+3.3V	18				
4	Red	+5V	18	150 +/- 15			
3	Black	GND	18				
2	Black	GND	18				
1	Yellow	+12V	18				

Note: All output cables are provided in black insulation. The color codes shown in the pin assignment table are for identification purposes only and are intended to represent the associated DC output voltage levels for reference.

